

Sorane

SA-1.2

I N S T R U C T I O N S

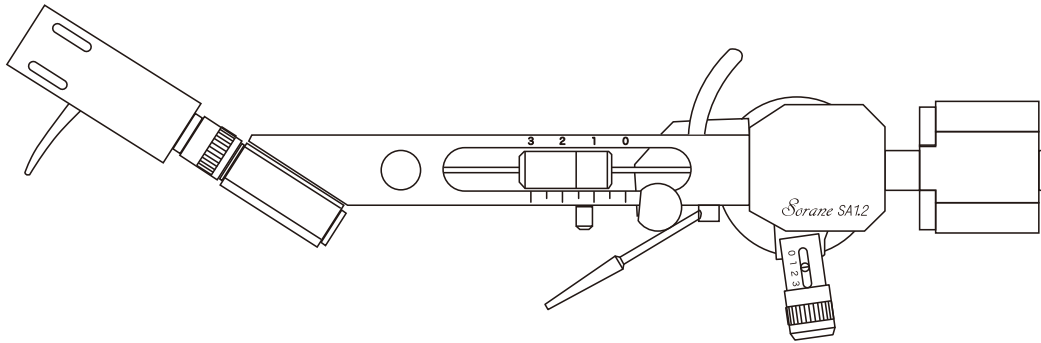

s p e c i f i c a t i o n s

Total Length ● 310mm

Effective Length (Tonearm pivot to cartridge stylus) ● 239mm

Practical Length (Tonearm pivot to spindle) ● 223mm

Overhang ● 16mm

Offset angle ● 22.25°

Horizontal moving sensitivity ● 30mg

Vertical moving sensitivity ● 20mg

Vertical Tracking Force (VTF) range ● 0-4.5g (3+1.5g)

Cartridge plus Headshell weight range ● 15-45g

Antiskating Adjustment ● 0-3g (Equivalent to Stylus VTF)

Vertical Bearing ● Miniature Radial Bearing

Horizontal Bearing ● Miniature Radial Bearing

Height Adjustment (Plinth to arm-wand centerline) ● 15-55mm

Output plug ● RCA (XLR as an Option)

Output cable ● Shielded stranded copper wire

Tonearm Audio Lead wire ● OFC 4N Copper

Headshell lead wire ● AWG30 Copper

Headshell ● Machine tooled Aluminum

Tonearm Net Weight ● 755g

Attached standard Headshell Net Weight ● 17g

Included Accessories

SA-1.2

Headshell

Weight

Base

Marking Pin & Bushing

Template

Detachable phono cable

Hex Keys

Screws, Washers

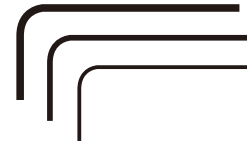

Thanks to Cylinder type Base's wider area bite between Sorane column shaft and TT plinth, sound improvement and stability would become dramatic by this parts.

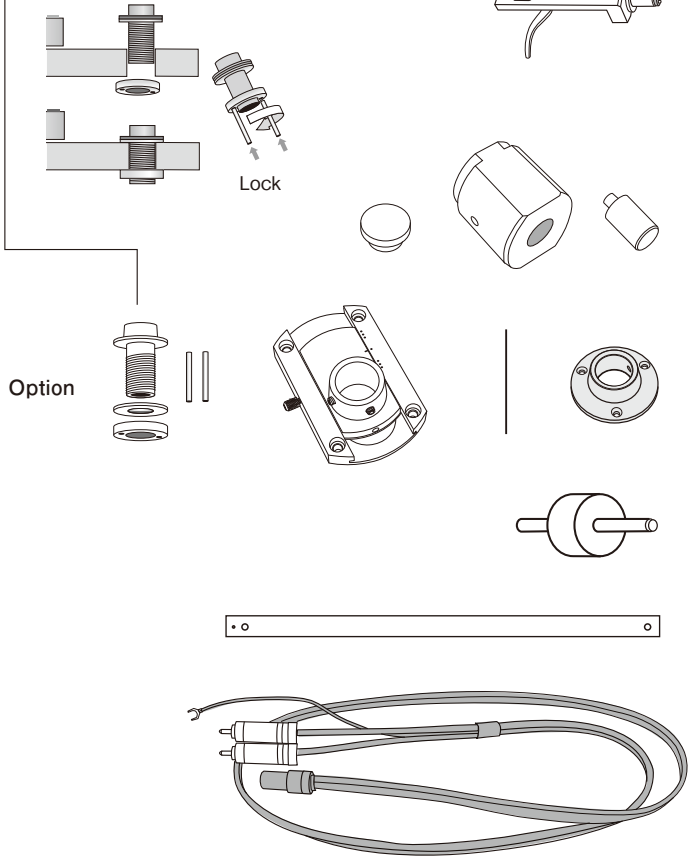

SME compatible sliding base,
SSBS,SSBB (Sorane Sliding Base Silver/Black)

Optional parts

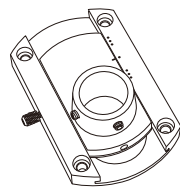

SSBS/B(Sorane Sliding Base with Silver/Black color) is optional parts to replace SME standard base for customer's convenience.
 Direction of sliding sub-base should point to the turntable spindle, while the mounting distance (the middle of the range of travel for the sliding base), is set by the mounting template.

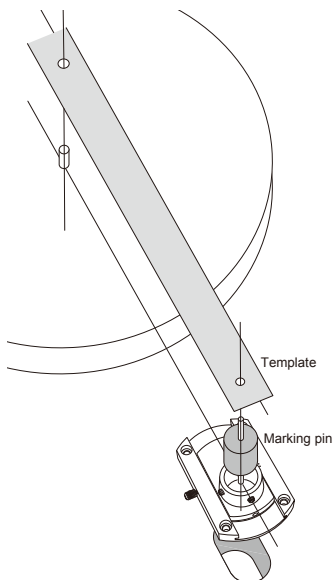

step1 Marking

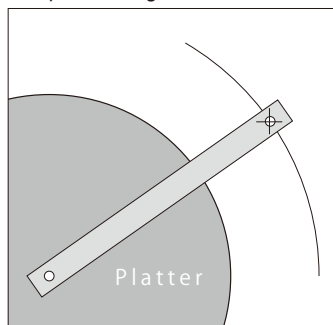

step2 Drilling

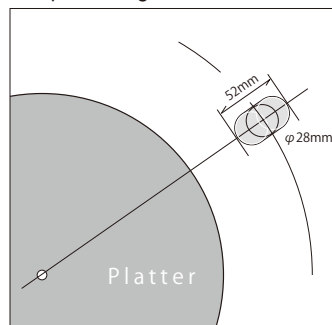

step3 Set up

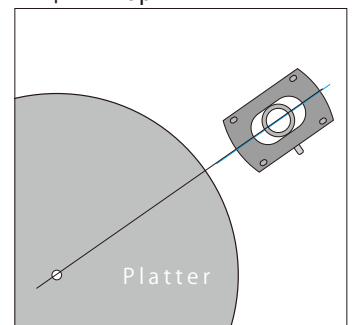

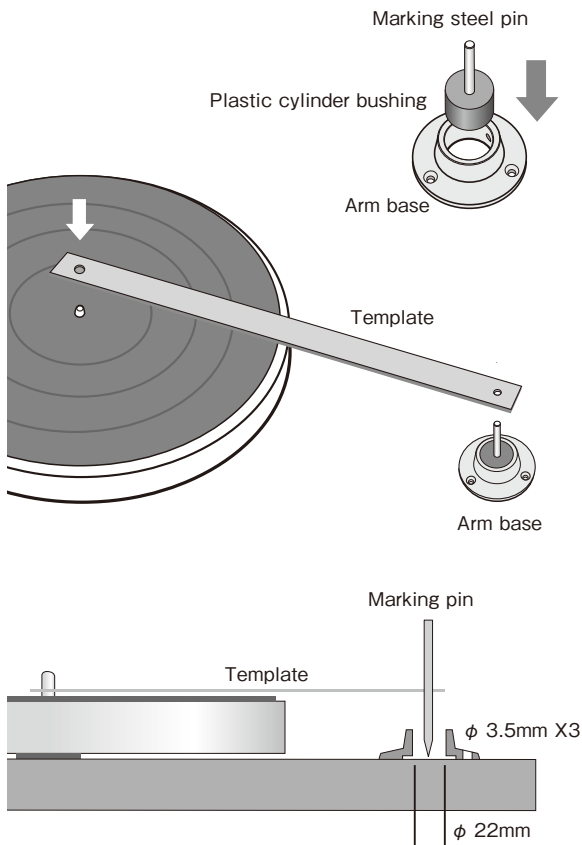

Mount the tonearm base to turntable plinth / Arm Board

1-a Determine where the arm base should be mounted by using the supplied arm mounting template.

1-b Put the larger hole of the template onto the center spindle. Take the attached marking pin supplied (as illustrated below) and push it through the small hole at the opposite end of the tonearm template (the hole opposite the spindle hole). Keep the needle perpendicular to the template. You may now mark the center point of the tonearm base. The center point of the tonearm base is also the pivot point.

1-c At the same time, mark the 3 holes for the screws that mount the arm base to the armboard.

1-d Do not drill holes yet !

1-e Having marked the center, check to see if there is sufficient clearance for the tonearm and the dust cover (if you have a dust cover). Pay particular attention to the counterweight shaft.

1-f After you have verified the dust cover will work with the chosen arm base location, drill one 22mm hole (this is the center, which allows access to the tonearm stem and cable) and three 3.5mm holes (for the screws that mount the arm base).

* 22mm diameter hole: For tonearm shaft!

* 3 x 3.5mm diameter holes: For tonearm base fixing screws!

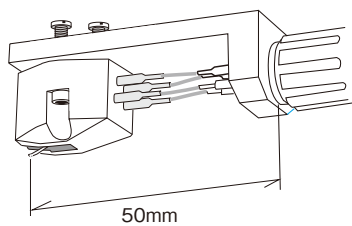

Attach the cartridge to headshell

Connect the wire leads to the cartridge pins, and attach the cartridge to the headshell with screws. (See the figure below) Screws are not included in this tonearm kit. They are usually included with the cartridge, from the cartridge manufacturer. in mm, will give accurate results.

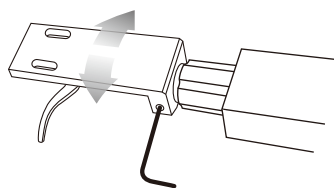

Headshell Azimuth Adjustment

6-a Sorane tonearms come with adjustable headshells. There is an Allen or hex set-screw in the side of the headshell. There is a corresponding Allen/Hex Key to allow the user to adjust the headshell.

6-b As shipped from the factory, the headshell adjustment Allen set-screw is set to approximately 90 degrees, with the intention that customers should adjust the headshell to match their unique setup (cartridge, plinth, platter, etc.). Customers are requested to make final adjustments after mounting the cartridge, then installing the headshell on your Sorane tonearm. It is important to make sure the stylus is perpendicular to the surface of the record. Often it is helpful to use a mirror (if you do not have a mirror, a CD will also work). The main thing is to understand that many stylus assemblies are not perfectly perpendicular, and sometimes platters are concave, so that it is important to adjust the stylus until it is perpendicular with the groove.

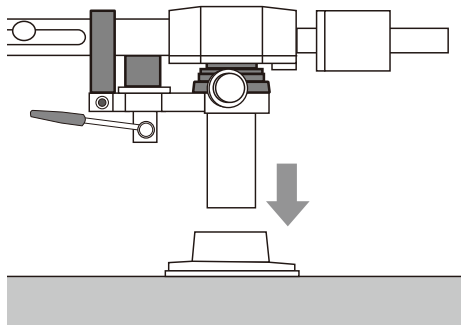

Mount SA-1.2 shaft through the Base hole

2-a Carefully push the tonearm shaft through the hole in the arm base and then fasten the set-screw with the hex key supplied with the tonearm. Be careful not to over tighten!

2-b Adjust the tonearm height to make the tonearm parallel with the surface of the record when the stylus is touching the record. This is the starting point, and further fine tuning may be necessary depending on the geometry and the stylus type of the cartridge. Consult the cartridge manufacturer for correct VTA and VTF!

2-c The cueing platform has already been set at the correct height but can be adjusted by using the supplied hex key.

Cartridge tracking force adjustment

3-a Verify that the anti-skating knob (number 3) is set at 0 grams.

3-b Ensure that the sliding tracking force adjustment knob (number 4) is set to zero (the point furthest to the back of the tonearm and closest to the pivot point).

3-c After the cartridge is correctly adjusted for overhang, adjust the counterweight (number 1) so that the arm is floating with the stylus approximately 3-5mm clear of the vinyl record. Once this adjustment is made, the counterweight should be fixed by the set-screw located on the side of the counterweight (number 2 below), using the supplied hex key.

3-d Add tracking force by using the sliding counterweight located in the middle of tone arm (number 4 below). As the middle counterweight slides forward, the tracking force increases. The tracking force can be increased to a maximum of 3.0 grams with the middle sliding counterweight pushed all the way forward to the headshell end of the tonearm (each step is equivalent to 0.5 grams x 6 steps, making 3 grams).

3-e The auxiliary weight is 1.5 grams (see 5). If more than 3 grams of tracking force is needed, as might be the case when playing 78 rpm records, place the ancillary weight in the hole as illustrated in the drawing (see 5). Only use this auxiliary weight if additional tracking force is needed! If it is not needed, store it away in a safe place.

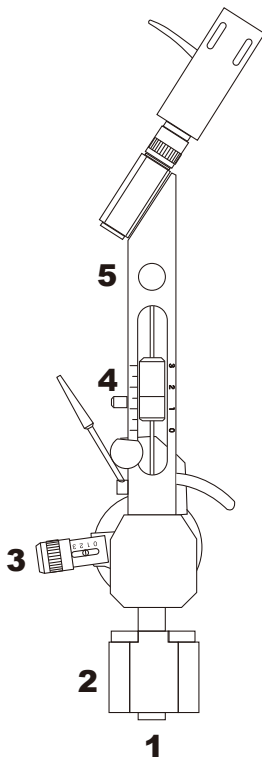

Example

If the tracking force needed is 3 grams, set the middle sliding counterweight at the mark for 3 grams on the weight gauge. If more than 3 grams of tracking force is needed, use the auxiliary weight of 1.5 grams, along with the counterweight, in order to secure your desired tracking force. For instance, the ancillary weight of 1.5 grams, plus 2.5 grams of tracking force set by the middle sliding counterweight, is equivalent to 4 grams total tracking weight.

Note

Because the tracking force mechanism (see 4) of SA-1.2BCS is different from a standard counterweight system, the use of a separate VTF gauge for precise fine-tuning is recommended. The relative accuracy of the SA-1.2 tracking force mechanism is somewhat affected by the complex interaction of the mass of the main counterweight, its position, the mass of the cartridge, and the mass of the headshell. So, as is usual with all tonearms, you should verify the desired tracking force with a calibrated VTF gauge.

Auxiliary counterweight stem

In case the standard counterweight is not heavy enough to balance your cartridge/headshell combination, an additional counterweight stem has been supplied to give additional mass, and greater range of adjustment.

4-a Remove the counterweight and headshell, setting them

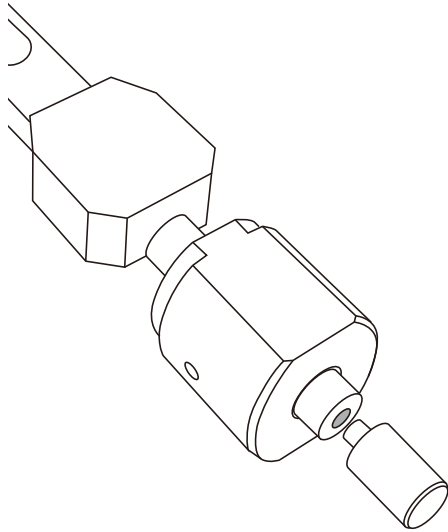

aside in a safe place.

4-b Inspect the threads on the auxiliary counterweight stem. If there is any debris, please brush it with a small paint brush, or clean toothbrush. Debris can cause the threads to become stuck.

4-c Attach the auxiliary stem by carefully threading clockwise into the main stem. The threads are normal “right-hand threaded”.

4-d Tighten firmly with your fingers, but do not apply aggressive force. Do not use a wrench, or other tool that would apply too much force on the bearings. Do not use thread-locking compound (removal would require excessive force). Finger-tighten only!

4-e The auxiliary counterweight stem provides two methods of counter-balancing heavier cartridges and headshells.

1–The weight of the auxiliary stem provides additional force.

2–The stem also provides much greater range of adjustment of the main counterweight (the zero-set counterweight).

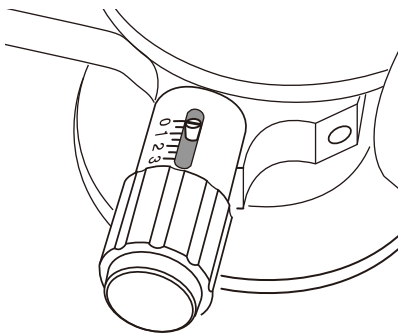

Anti-skating (bias) adjustment

Set the bias adjustment knob to the same number as the tracking force. Some experimentation may be necessary based on the specific stylus profile used by the cartridge.

Thank you for choosing Sorane! As IT Industry values the customer, and strives to offer the best performance, we are sure you will enjoy many hours of clear and dynamic sound.
Happy listening!